

Electrical Standard Products (ESP) Branch Offices:

REGISTERED OFFICE AND HEAD OFFICE

L&T House, Ballard Estate
P. O. Box 278
Mumbai 400 001
Tel: 022-67525656
Fax: 022-67525858
Website: www.Larsentoubro.com

ELECTRICAL STANDARD PRODUCTS (ESP)

501, Sakar Complex I
Opp. Gandhigram Rly. Station
Ashram Road
Ahmedabad 380 009
Tel: 079-66304006-11
Fax: 079-66304025
e-mail: esp-ahm@LNTEBG.com

38, Cubbon Road, P. O. Box 5098
Bangalore 560 001
Tel: 080-25020100 / 25020324
Fax: 080-25580525
e-mail: esp-blr@LNTEBG.com

131/1, Zone II
Maharana Pratap Nagar
Bhopal 462 011
Tel: 0755-3080511 / 05 / 08 / 13 / 17 / 19
Fax: 0755-3080502
e-mail: esp-bho@LNTEBG.com

Plot No. 559, Annapurna Complex
Levis Road
Bhubaneswar 751 014
Tel: 0674-6451342, 2436690, 2436696
Fax: 0674-2537309
e-mail: nayakd@LNTEBG.com

Aspire Towers, 4th Floor
Plot No. 55, Phase-I
Industrial & Business Park
Chandigarh-160 002
Tel: 0172-4646840 / 41 / 42 / 46 / 53
Fax: 0172-4646802
Email: esp-chd@Lntebg.com

L&T Construction Campus
TC-1 Building, II Floor
Mount-Poonamallee Road
Manapakkam
Chennai 600 089
Tel: 044-2270 6800
Fax: 044-22706940
e-mail: esp-maa1@LNTEBG.com

67, Appuswamy Road
Post Bag 7156
Opp. Nirmala College
Coimbatore 641 045
Tel: 0422-2588120 / 1 / 5
Fax: 0422-2588148
e-mail: esp-cbe@LNTEBG.com

Khairasol, Degaul Avenue
Durgapur 713 212
Tel: 2559848, 2559849, 2559844
Fax: 0343-2553614
e-mail: esp-dgp@LNTEBG.com

5, Milanpur Road, Bamuni Maidan
Guwahati 781 021
Tel: +91 8876554410 / 8876554417
Fax: 361-2551308
e-mail: hazrasudipto@LNTEBG.com

II Floor, Vasantha Chambers
5-10-173, Fateh Maidan Road
Hyderabad 500 004
Tel: 040-67015052
Fax: 040-23296468
e-mail: esp-hyd@LNTEBG.com

Monarch Building, 1st Floor
D-236 & 237, Amrapali Marg
Vaishali Nagar
Jaipur 302 021
Tel: 0141-4385914 to 18
Fax: 0141-4385925
e-mail: esp-jai@LNTEBG.com

Akashdeep Plaza, 2nd Floor
P. O. Golmuri
Jamshedpur 831 003
Jharkhand
Tel: 0657-2312205 / 38
Fax: 0657-2341250
e-mail: esp-jam@LNTEBG.com

Skybright Bldg; M. G. Road
Ravipuram Junction, Ernakulam
Kochi 682 016
Tel: 0484-4409420 / 4 / 5 / 7
Fax: 0484-4409426
e-mail: esp-cok@LNTEBG.com

3-B, Shakespeare Sarani
Kolkata 700 071
Tel: 033-44002572 / 3 / 4
Fax: 033-22821025 / 7587
e-mail: esp-ccu@LNTEBG.com

A28, Indira Nagar, Faizabad Road
Lucknow 226 016
Tel: 0522-4929905 / 04
Fax: 0522-2311671
e-mail: esp-lko@LNTEBG.com

No: 73, Karpaga Nagar, 8th Street
K. Pudur
Madurai 625 007
Tel: 0452-2537404, 2521068
Fax: 0452-2537552
e-mail: esp-mdu@LNTEBG.com

L&T Business Park,
Tower 'B' / 5th Floor
Saki Vihar Road, Powai
Mumbai 400 072
Tel: 022-67052874 / 2737 / 1156
Fax: 022-67051112
e-mail: esp-bom@LNTEBG.com

12, Shivaji Nagar
North Ambajhari Road
Nagpur 440 010
Tel: 0712-2260012 / 6606421
Fax: 2260030 / 6606434
e-mail: esp-nag@LNTEBG.com

32, Shivaji Marg
P. O. Box 6223
New Delhi 110 015
Tel: 011-41419514 / 5 / 6
Fax: 011-41419600
e-mail: esp-del@LNTEBG.com

L&T House
P. O. Box 119
191/1, Dhole Patil Road
Pune 411 001
Tel: 020-66033395 / 66033279
Fax: 020-26164048 / 26164910
e-mail: esp-pnq@LNTEBG.com

Crystal Tower,
4th Floor, G. E. Road
Telibandha
Raipur - 492 006
Tel: 0771-4283214
e-mail: esp-raipur@LNTEBG.com

3rd Floor
Vishwakarma Chambers
Majura Gate, Ring Road
Surat 395 002
Tel: 0261-2473726
Fax: 0261-2477078
e-mail: esp-sur@LNTEBG.com

Radhadaya Complex
Old Padra Road
Near Charotar Society
Vadodara 390 007
Tel: 0265-6613610 / 1 / 2
Fax: 0265-2336184
e-mail: esp-bar@LNTEBG.com

Door No. 49-38-14/3/2, 1st floor,
NGGO's Colony, Akkayyapalem,
Visakhapatnam - 530 016
Tel: 0891 2791126, 2711125
Fax: 0891 2791100
Email: esp-viz@LNTEBG.com

Product improvement is a continuous process. For the latest information and special applications, please contact any of our offices listed here.



Larsen & Toubro Limited, Electrical Standard Products
Powai Campus, Mumbai 400 072

Customer Interaction Center (CIC)

BSNL / MTNL (toll free): 1800 233 5858 Reliance (toll free): 1800 200 5858
Tel: 022 6774 5858 Fax: 022 6774 5859 Email: cic@Lntebg.com
Web: www.Lntebg.com

Regd. Office: L&T House, N. M. Marg, Ballard Estate, Mumbai - 400 001. INDIA Tel: +91 22 6752 5656 CIN: L99999MH1946PLC004768



High on compactness
big on reliability



Cx2000 AC Drive

Single Phase 230V (0.1 ~ 2.2kW)
Three Phase 230V (0.2 ~ 11kW)
Three Phase 415V (0.75 ~ 11kW)



SP-50697 CBM/C/PRD/122014

Two decades of application knowledge

For over two decades, various industry sectors have been reaping the benefits of L&T's cost-effective, performance-oriented AC Drive solutions. L&T's grasp of the specific needs of each industry enables it to offer application-specific solutions for various industries – such as processing, textile, plastic, ceramic, pharmaceutical, elevator, oil & gas, power, cement and material-handling.



Cx2000 AC Drive

› The new **reliability** edge

The Cx2000 adds a new dimension to L&T's AC drive solutions. Built to L&T's stringent quality standards, the Cx2000 is tested and certified to meet global benchmarks, thus giving you the assurance of total reliability.



Compact, lightweight, easy to install, operate and service – the Cx2000 is perfectly suited for conveyors, pumps, fans and textile machinery. It handles loads up to 11 kW, and is engineered to keep your machine operating at optimum efficiency, even in the hot, humid and dusty conditions that characterise India's industrial environment.



Meeting your needs, solving your problems

We believe in addressing your needs and not just selling a product. That's why a dedicated Solutions Team first focuses on understanding your application. Then helps you select the drive that best meets your needs. Our advice on installation, maintenance and replacement will ensure that your machines function at peak productivity. From engineer to repair technician, our people have the knowledge and skill-sets to deliver total peace of mind.

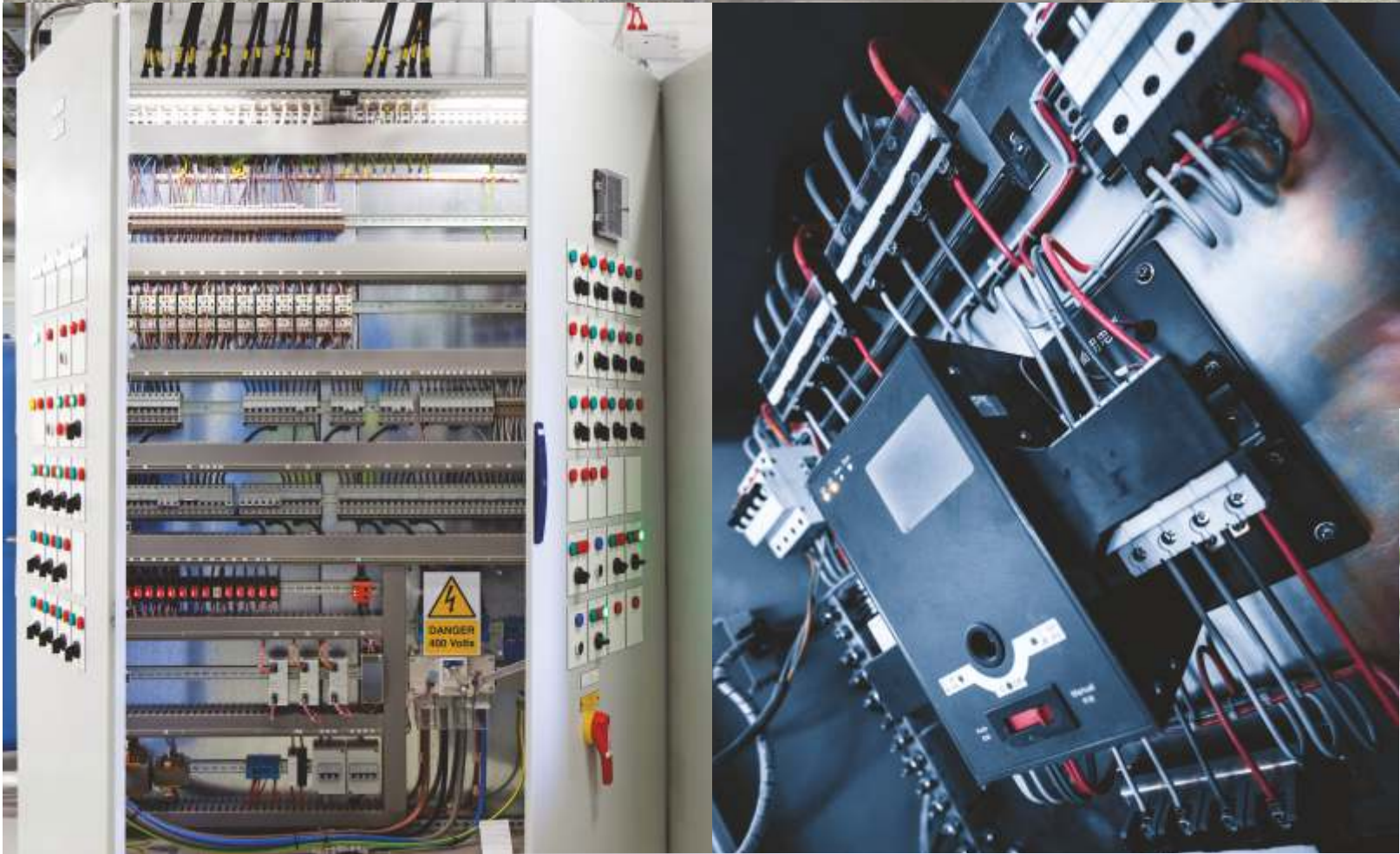

Backed by engineering knowledge across seven decades

A knowledge-based company, L&T brings you the benefits of over 75 years of engineering experience and expertise, and the richness of its collaborations with technology leaders across the globe.

For 50 years, L&T's low-tension switchgear – India's widest range – has been the preferred option of top industrial houses countrywide.



➤ **Tested. Certified. Reliable.**

L&T is one of the few switchgear manufacturers in India with a dedicated, NABL-certified testing facility. Our products are tested for conformity to standards that exceed minimum requirements, giving you the assurance of high-quality performance. Our focus on continuous improvement ensures that our standards are on par with the best in the world. Repeat orders endorse the value that we deliver.

The reliability of the Cx2000 is ensured by international test certification – UL, CE and RoHS.

Ready Spares

➤ **After-sales service** aimed at maximum uptime

A malfunction of the drive can bring an entire assembly line or process to a halt. To ensure maximum uptime for you, our Rapid Response service team is available to analyze the situation and help you set the problem right. We have set up strategic service centres across the country to provide temporary replacement drives or ready spares to ensure that your business keeps running smoothly.

Rapid Response Service Team



➤ **Training your people** to enhance your operations

At our countrywide Switchgear Training Centres, we can train your operators, electricians and supervisors to increase their effectiveness in the operation, maintenance and trouble-shooting of your drives. We can also conduct in-plant training and workshops at your premises to improve both power management and equipment maintenance skills. This gives you total operational excellence, minimizing downtime.

L&T's engineers and channel partners also upgrade their skills through seminars, workshops, training sessions and white papers on electrical practices.

Features that ensure performance

- Sensorless Vector Control
- Integrated Potentiometer
- Inbuilt PID
- Torque Boost for Forward and Reverse direction
- Draw Mode
- Hardware Base Block
- Inbuilt 24V power source
- Component Life Monitor
- RS485 Modbus Communication



Cx2000

Provides **Optimized Solutions** to Global Customers

the cost effective and easy-to-install, compact drive will enhance your machine's performance



Side-by-Side Installation

The panel size can be significantly reduced thanks to the Cx2000's side-by-side installation.



KEB for Safe Operating Stop in the Event of Power Failure

By using the regenerated power from the decelerating load, the KEB function automatically protects the machine by providing safe (controlled) braking in case of a power outage.

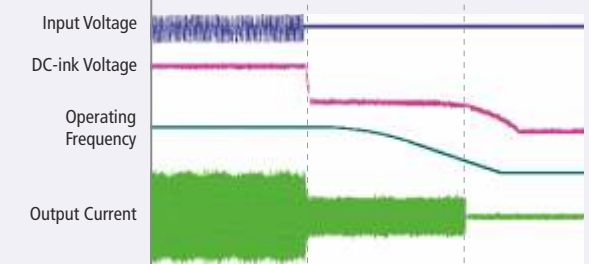

Compliance with Safety Requirements

- If a machine needs safe standstill functionality in case of emergency, the connection of SA, SB, and SC terminals that is shorted normally will be opened to block the drive output.
- Easy to comply with safety requirements at the system level by adding safe input functions complying with EN ISO 13849-1 Pld and EN61508SIL2 [EN60204-1, stop category 0]

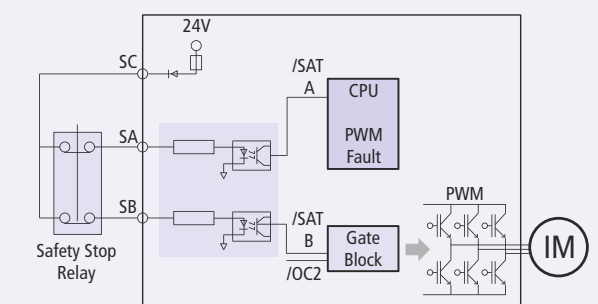

Note: Safety relay not included



› Convenient

Simple operation and easy maintenance features enhance your convenience.



Compact Drive
Cx2000

Features



› User Convenience through Simple Operation

- Integrated Potentiometer
- Possible to add reference from keypad and external signal
 - Provides external potentiometer for easier frequency control
 - Additional 0-5V analog input for frequency control

› Easy Fan Maintenance

You can easily replace a fan without opening the drive cover



› Dual Rating

Designed to select between heavy and light load

Overload	Heavy load operation: 150% of rated current, 60 sec.
Withstand	Light load operation: 110% of rated current, 60 sec.

› PC-based Software for Easy Maintenance of Drive and Motor Parameters

- DriveConnect** software allows drive/system monitoring on a PC and easy maintenance of drive and motor parameters
- Windows-based graphic user interface (GUI)
 - Modbus-RTU
 - Connecting up to 31 drives
 - Integrated control console
 - Offline editing function
 - Data upload/download
 - 4-channel oscilloscope
 - Trigger function





➤ Input and Output Specifications: **Input Voltage Single-phase (230V)**

LTVF-C1 □□□□ BAA		0001	0002	0003	0005	0008	0011
Applicable Motor ¹⁾	HP	1/8	1/4	1/2	1	2	3
	kW (HD)	0.1	0.2	0.4	0.75	1.5	2.2
Output Ratings	Rated Capacity [kVA] (HD)	0.3	0.5	1.0	1.9	3.0	4.2
	Rated Current [A] ²⁾ (HD)	0.8	1.4	2.5	5.0	8.0	11
	Max. Output Frequency	400 [Hz] ³⁾					
	Max. Output Voltage [V]	Three-Phase 200 ~ 240V ⁴⁾					
Input Ratings	Rated Voltage [V]	Single-Phase 200 ~ 240 VAC (-15% ~ +10%)					
	Rated Current [A]	1.4	2.8	5.5	11	14.1	24
	Rated Frequency	50 ~ 60 [Hz] (±5%)					
Cooling Type	Natural Cooling			Forced Cooling			

➤ Input and Output Specifications: **Input Voltage Three-phase (230V)**

LTVF-C2 □□□□ BAA			0001	0002	0003	0006	0010	0012	0018	0030	0040
Applicable Motor ¹⁾	HD	[HP]	0.12	0.25	0.5	1	2	3	5	7.5	10
		[kW]	0.1	0.2	0.4	0.75	1.5	2.2	3.7	5.5	7.5
	ND	[HP]	0.25	0.5	1	1.5	3	4	5.4	10	15
		[kW]	0.2	0.4	0.75	1.1	2.2	3.0	4.0	7.5	11.0
Output Ratings	Rated Capacity [kVA]	HD	0.3	0.5	1.1	1.9	3.0	4.	6.1	9.1	12.2
		ND	0.4	0.7	1.3	2.4	3.8	5.2	7.6	12.1	16.3
	Rated Current [A] ²⁾	HD	0.8	1.4	2.5	5.0	8.0	11.0	16.0	24.0	32.0
		ND	1.1	1.8	3.1	6.3	10.0	12.0	18.0	30.0	40.0
Max. Output Frequency		400 [Hz] ³⁾									
Max. Output Voltage [V]		Three-Phase 200 ~ 240V ⁴⁾									
Input Ratings	Rated Voltage [V]	Three Phase 200 ~ 240 VAC (-15% ~ +10%)									
	Rated Current [A] ²⁾	HD	0.7	1.5	2.0	5.8	7.5	11.0	8.9	22.1	28.6
		ND	1.1	1.9	3.9	7.3	10.8	13.9	24	28.6	41.2
Rated Frequency		50 ~ 60 [Hz] (±5%)									
Cooling Type	Natural Cooling					Forced Cooling					

➤ Input and Output Specifications: **Input Voltage Three-phase (415V)**

LTVF-C4 □□□□ BAA			0002	0003	0005	0007	0010	0016	0023	
Applicable Motor ¹⁾	HD	[HP]	0.5	1.0	2.0	3.0	5.0	7.5	10.0	
		[kW]	0.4	0.75	1.5	2.2	3.7	5.5	7.5	
	ND	[HP]	1	1.5	3	4	5.4	10	15	
		[kW]	0.75	1.1	2.2	3.0	4.0	7.5	11.0	
Output Ratings	Rated Capacity [kVA]	HD	1.0	1.9	3.0	4.2	6.1	9.1	12.2	
		ND	1.2	2.4	3.8	5.2	7.6	12.1	16.3	
	Rated Current [A] ²⁾	HD	1.25	2.5	4.0	5.5	8.0	12.0	16.0	
		ND	2.0	3.1	5.1	6.9	10.0	16.0	23.0	
Max. Output Frequency		400 [Hz] ³⁾								
Max. Output Voltage [V]		Three-Phase 380 ~ 480V ⁴⁾								
Input Ratings	Rated Voltage [V]	Three-Phase 380 ~ 480 VAC (-15% ~ +10%)								
	Rated Current [A] ²⁾	HD	1.8	3.2	4.4	6	10.4	11.0	14.4	
		ND	2.1	4.3	5.9	8.1	14	14.7	21.9	
Rated Frequency		50 ~ 60 [Hz] (±5%)								
Cooling Type	Natural Cooling					Forced Cooling				

Note 1) - Indicates the maximum applicable motor capacity when using a 4-pole standard motor.
 Note 2) - When Carrier frequency setting (H39) is 6kHz or less.
 Note 3) - The max. frequency setting range can be 120Hz when H40 is set to 3 (Sensorless vector control)
 Note 4) - The maximum output voltage cannot be higher than the input voltage and it can be programmable below input voltage.

Control

Control Type	V/F control, sensorless vector control, slip compensation	
Frequency Precision Setting	Digital command: 0.01Hz Analog command: 0.05Hz (Max. frequency: 50Hz)	
Frequency Precision	Operation by digital command: 0.01% of max. output frequency. Analog command operation: 0.1% of max. output frequency.	
V/F Pattern	Linear, squared, user V/F	
Overload Capacity	HD : 150%/ 1min; ND: 110%/ 1min	
Torque Compensation	Manual/Auto torque compensation	
Dynamic Torque 20% Braking	Max. Brake Torque	20% ¹⁾
	Time/%ED	150% ²⁾ when using optional DB resistor

Note - 1) Average braking torque during Decel to stop a motor. Note - 2) Refer to technical manual for DB resistor specification.

Operation

Operation Mode	Keypad / Terminal / Communication operation	
Frequency Setting	Analog type: 0 ~ 10[V], 0 ~ 20[mA] Digital type: Keypad Panel potentiometer	
Operational Functions	PID control, Up-Down operation, 3-wiring operation, Draw Mode	
Input	P1 ~ P5 Multi-function Terminals (5 points) P1 ~ P5	PNP / NPN Selectable Functions: Forward/Reverse operation, emergency stop, fault reset, jog operation, multi-step frequency – high, mid and low, multi-step accel/ decel- high, mid, low, DC braking at stop, 2 nd motor select, up/down operation function (increase/decrease of frequency), 3-wire operation, external fault signal input (contact A/B), general operation switched during PID operation, 2 nd source, analog hold, accel/decel stop, up/down save freq, jog forwards/reverse operation.
	Analog Input	Signal Input: 0-10V, 0-20mA (programmable)
	Output	Multi-function Relay
	Analog Output	0 ~ 10Vdc (less than 10mA): Choose among output freq, output current, output voltage, DC link selectable.

Protective Function

Faults	Over voltage, low voltage, over current, short circuit, ground current detection, drive overheat, motor overheat, input and output phase loss, overload protection, communication error, loss of frequency command, hardware fault, cool fan trip, brake error.
Alarm	Stall prevention, overload
Momentary Power Loss ¹⁾	Below 16 msec: Continuous operation Above 16 msec: Auto restarting.

Note - 1) the rated input voltage is 220V for 230V class, 440V for 415V class, and the rated input is subject to HD.

Structure and Application Environment

Protection Degree	Opening (IP 20)
Ambient Temperature	HD operation: - 10 ~ 50°C (no freezing) ND operation: - 10 ~ 40°C (no freezing) (For operation at 50°C, if the drive adopts HD load, it is recommended to use the load at 80%).
Storage Temperature	-20°C ~ 65°C
Relative Humidity	Below relative humidity 90% RH (no condensation)
Altitude/Vibration	Below 1000m, 5.9/sec ² (0.6G)
Atmospheric Pressure	70~106 kPa
Installation Environment	No corrosive air, combustible gas, oil mist, etc.

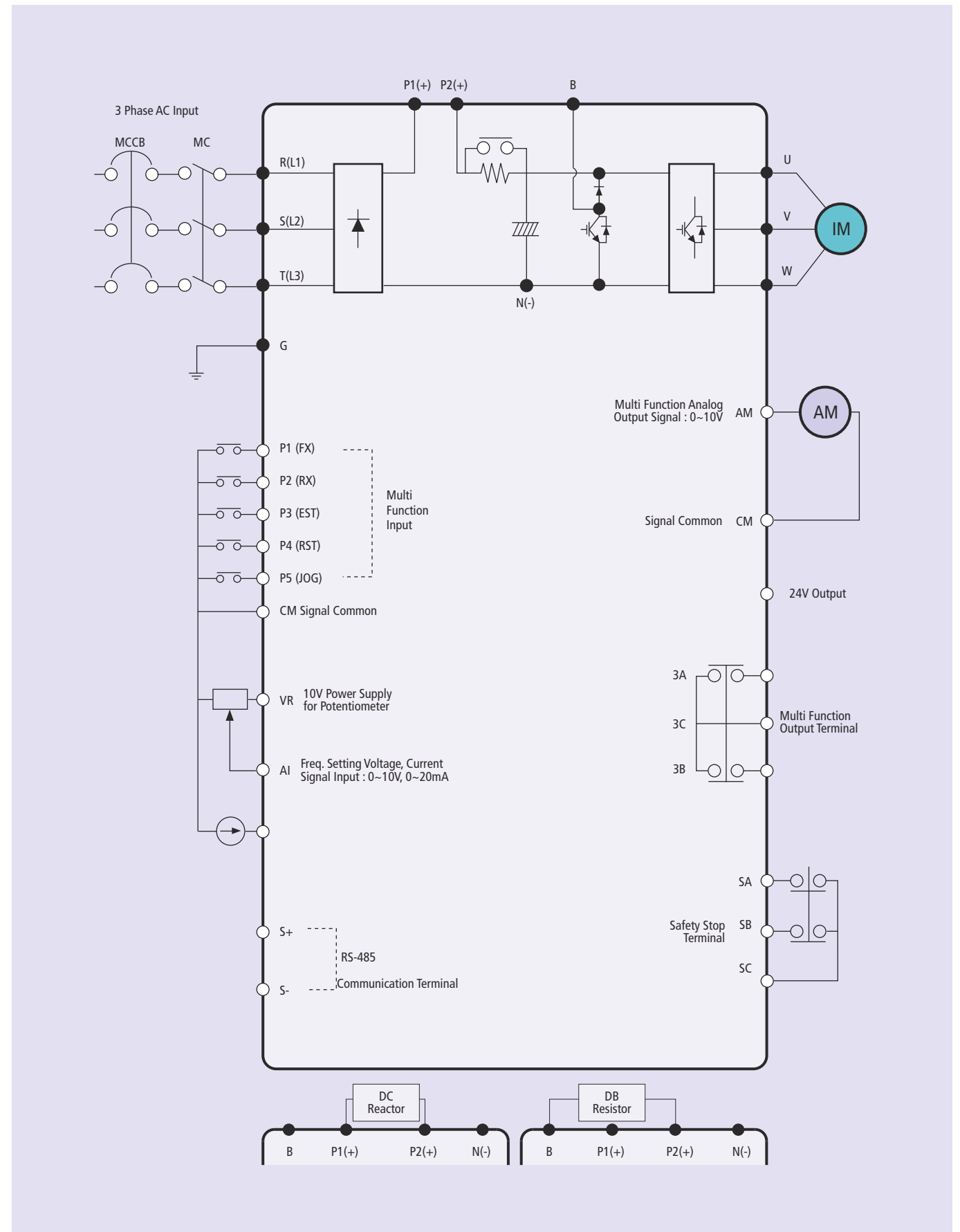

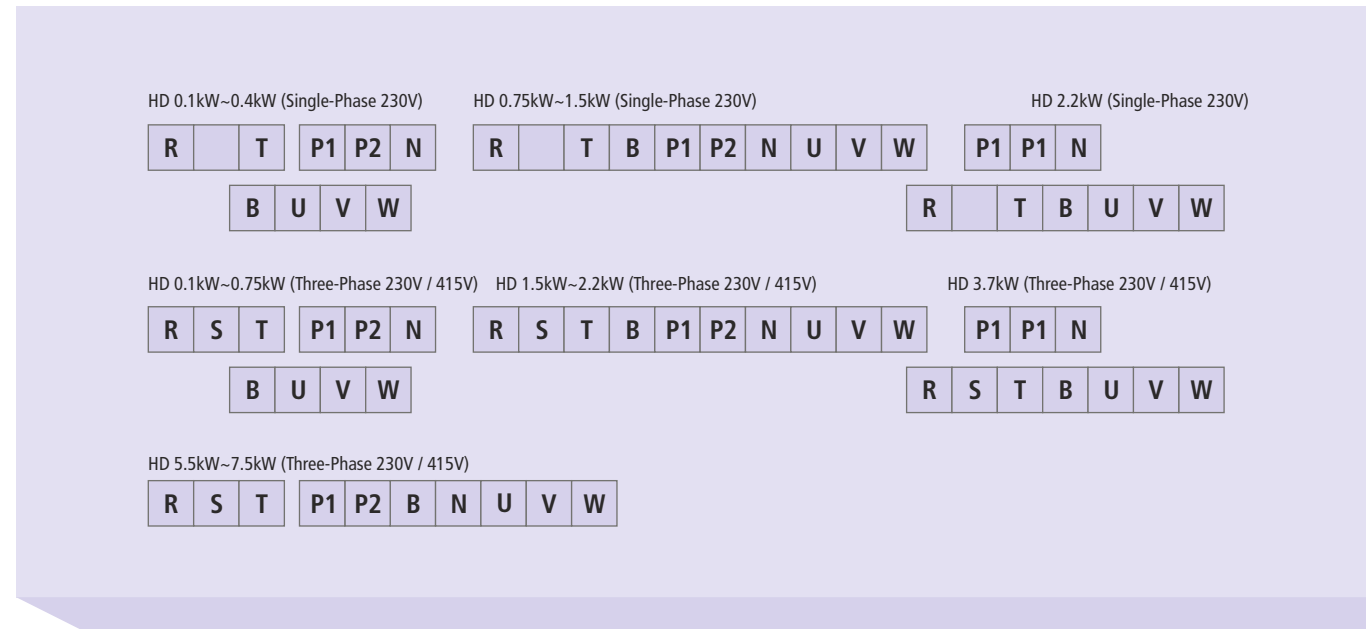

Cat. Nos.	HD kW	R.S.T Size		U,V,W Size		Ground Size		Terminal Screw Size	Screw Torque (kgf.cm)
		mm ²	AWG	mm ²	AWG	mm ²	AWG		
LTVF-C10001BAA	0.1	2	14	2	14	3.5	12	M3.5	10
LTVF-C10002BAA	0.2	2	14	2	14	3.5	12	M3.5	10
LTVF-C10003BAA	0.4	2	14	2	14	3.5	12	M3.5	10
LTVF-C10005BAA	0.75	2	14	2	14	3.5	12	M3.5	10
LTVF-C10008BAA	1.5	2	14	2	14	3.5	12	M3.5	10
LTVF-C10011BAA	2.2	3.5	12	3.5	12	3.5	12	M4	12.2
LTVF-C20001BAA	0.1	2	14	2	14	3.5	12	M3.5	10
LTVF-C20002BAA	0.2	2	14	2	14	3.5	12	M3.5	10
LTVF-C20003BAA	0.4	2	14	2	14	3.5	12	M3.5	10
LTVF-C20006BAA	0.75	2	14	2	14	3.5	12	M3.5	10
LTVF-C20010BAA	1.5	2	14	2	14	3.5	12	M3.5	10
LTVF-C20012BAA	2.2	2	14	2	14	3.5	12	M3.5	10
LTVF-C20018BAA	3.7	3.5	12	3.5	12	3.5	12	M4	12.2
LTVF-C20030BAA	5.5	6	10	6	10	5.5	10	M4	15
LTVF-C20040BAA	7.5	6	10	6	10	5.5	10	M4	15
LTVF-C40002BAA	0.4	2	14	2	14	2	14	M3.5	10
LTVF-C40003BAA	0.75	2	14	2	14	2	14	M3.5	10
LTVF-C40005BAA	1.5	2	14	2	14	2	14	M3.5	10
LTVF-C40007BAA	2.2	2	14	2	14	2	14	M3.5	10
LTVF-C40010BAA	3.7	3.5	12	3.5	12	2	14	M4	12.2
LTVF-C40016BAA	5.5	3.5	12	3.5	12	3.5	12	M4	13.8
LTVF-C40023BAA	7.5	3.5	12	3.5	12	3.5	12	M4	13.8

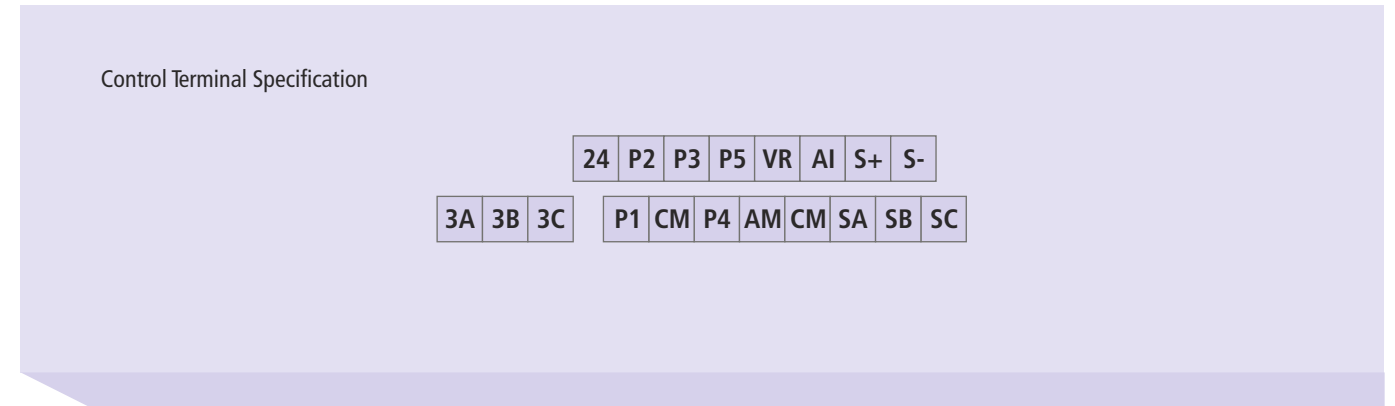

T/M	Terminal Description	Wire Size (mm ²)		Screw Size	Torque [Nm]	Specification
		Single Wire	Stranded			
P1~P5	Multi-function input terminal P1-P5	1.0	1.5	M2.6	0.4	
CM	Common terminal	1.0	1.5	M2.6	0.4	
VR	Power supply for analog	1.0	1.5	M2.6	0.4	Output voltage: 12V, Max output current: 10mA Potentiometer: 1 ~ 5kohm
AI	Analog (voltage and current) input terminal	1.0	1.5	M2.6	0.4	Input voltage: 0~10V Input current: 0 ~ 20mA, Internal resistance: 250 Ω
AM	Multi-function analog output terminal	1.0	1.5	M2.6	0.4	Max output voltage: 11[V], Max output current: 10mA
S+	RS485 communication terminal	1.0	1.5	M2.6	0.4	
S-	RS485 communication terminal	1.0	1.5	M2.6	0.4	
24	External 24V power supply	1.0	1.5	M2.6	0.4	Max output current: 100mA
3A	Multi-function relay output A	1.0	1.5	M2.6	0.4	AC 250V, less than 1A DC 30V, less than 1A
3B	Multi-function relay output B	1.0	1.5	M2.6	0.4	
3C	Multi-function relay common terminal	1.0	1.5	M2.6	0.4	
SA	Safe stop connection terminal A	1.0	1.5	M2.6	0.4	
SB	Safe stop connection terminal B	1.0	1.5	M2.6	0.4	
SC	Safety power supply (24V)	1.0	1.5	M2.6	0.4	

Note 1) - Tie the control wires more than 15cm away from the control terminals. Otherwise, it interferes front cover reinstallation.
 Note 2) - Use copper wires rated 600V, 75 °C and higher.
 Note 3) - Use the recommended tightening torque when securing terminal screws.



Display	Key	Description
	RUN	Run command
	STOP/RESET	STOP: Stop command during operation RESET: Reset command when fault occurs
	Up	Used to move parameter codes or increase parameter values
	Down	Used to move parameter codes or increase parameter values
	Left	Used to switch parameter groups or move the cursor to the left when the parameters are written
	Right	Used to switch parameter groups or move the cursor to the right when the parameters are written
	ENT	Used to read, write and keep the parameter values
	Potentiometer	The keypad potentiometer V2 is used for frequency setting
FWD	Forward	Lit during forward run
REV	Reverse	Lit during reverse run
RUN	Running	Lit during operation
SET	Setting	Lit during parameter setting
7-segment	Current Values	

Blinks when a fault occurs

Braking Resistors

Input Voltage	Motor [kW]	100% Braking		150% Braking	
		Resistance[W]	P ¹ [W]	Resistance[W]	P ¹ [W]
230V	0.1	1200	20	1000	20
	0.2	700	25	500	35
	0.4	400	50	300	100
	0.75	200	100	150	150
	1.5	100	200	60	300
	2.2	60	300	50	400
	3.7	40	500	33	600
	5.5	30	700	20	800
415V	7.5	20	1000	15	1200
	0.4	1800	50	1200	100
	0.75	900	100	600	150
	1.5	450	200	300	300
	2.2	300	300	200	400
	3.7	200	500	130	600
	5.5	120	700	85	1000
	7.5	90	1000	60	1200

Peripheral Devices

MCCB (Molded Case Circuit Breaker) and MC (Magnetic Contactor)

Input Voltage	Drive Model	MCCB (L&T)	MC (L&T)
Single-Phase 230V	LTVF-C10001BAA	DM16/2.5	MNX 9-2P
	LTVF-C10002BAA	DM16/6.3	MNX 9-2P
	LTVF-C10003BAA	DM16/12	MNX 9-2P
	LTVF-C10005BAA	DM100/25	MNX 9-2P
	LTVF-C10008BAA	DM100/30	MNX 12-2P
	LTVF-C10011BAA	DM100/50	MNX 18-2P
Three-Phase 230V	LTVF-C20001BAA	DM16/2.5	MO9
	LTVF-C20002BAA	DM16/4	MO9
	LTVF-C20003BAA	DM16/7.5	MO9
	LTVF-C20006BAA	DM16/16	MO9
	LTVF-C20010BAA	DM100/25	MO-12
	LTVF-C20012BAA	DM100/25	MO-18
	LTVF-C20018BAA	DM100/50	MO-32
	LTVF-C20030BAA	DM100/60	MO-40
Three-Phase 415V	LTVF-C20040BAA	DM100/80	MO-50
	LTVF-C40002BAA	DM16/5	MO9
	LTVF-C40003BAA	DM16/10	MO9
	LTVF-C40005BAA	DM16/12	MO9
	LTVF-C40007BAA	DM16/16	MO-12
	LTVF-C40010BAA	DM100/30	MO-18
	LTVF-C40016BAA	DM100/30	MO-32
	LTVF-C40023BAA	DM100/50	MO-32

Warning: 1) MC(Magnetic Contactor) current is 1.5-2.0 times of the drive's rated current

2) MCCB should be used to protect against overload and to avoid damage of installation of drive from the fault current (the Cx2000 has the overload capacity of 150% for 1 min)

